

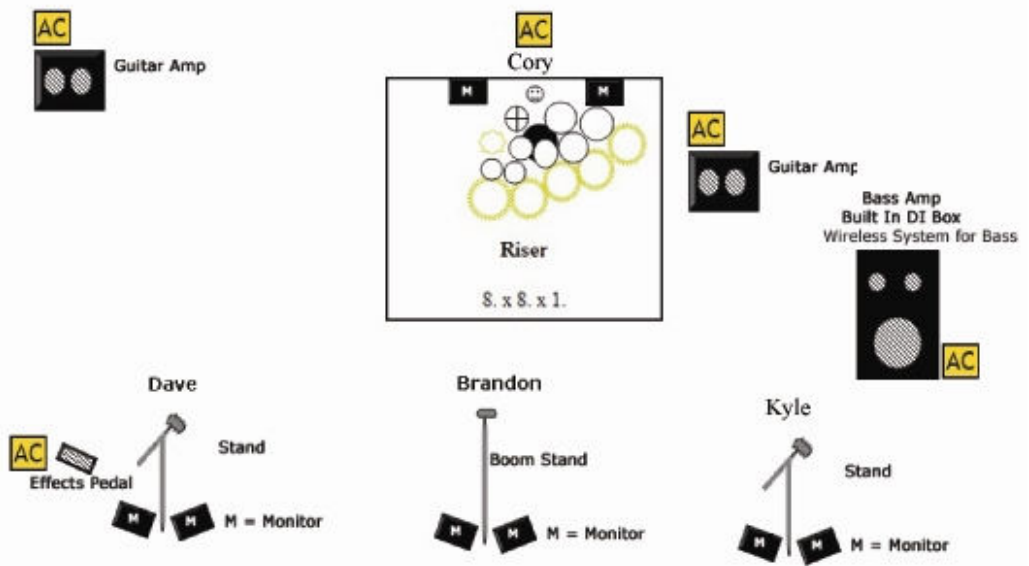

# Input List & Stage Plot



## **SOUND / LIGHTING REQUIREMENTS**

### **1) MUSICIANS FOR Mystic Kick:**

**Brandon** (Lead Vocals)

**Dave** (Guitarist & BG Vocals)

**Kyle** (Bassist & BG Vocals)

**Cory** (Drummer)

### **2) MUSICAL DESCRIPTION:** Alternative Rock /Rock / Classic Rock

**3) MAIN SPEAKERS:** We are looking for clear / crisp vocal reproduction over the normal vocal range and a general sound system that is used by a rock quartet with enough power for clean Highs, Mids with no-feedback, and tight low-end punch To cover the entire audience area. A bit of a trail on vocals.

### **4) STAGE MONITOR REQUIREMENTS:**

Two wedge stage floor monitor for each musician (8 total) with high and low speaker output using a double Monitor mix if possible.

### **5) LIGHTING:** Lighting should cover entire stage area.

**6) POWER:** Please provide 110 AC power to stage. Power drops Need to be behind Bass Amplifier, Drum Riser, Guitar Amplifier, and Front for Guitar Effects.

### **7) INPUT LIST**

**Ch. Instrument Mic's.**

#### ***Drums:***

- 1) Kick Drum
- 2) Snare Top
- 3) Snare Bottom
- 4) Hi Hat
- 5) Floor Tom 1
- 6) Rack Tom 1
- 7) Rack Tom 2
- 8) Ride Symbol
- 9) Crash 1
- 10) Crash 2
- 11) Crash 3

**Bass:**

- 17) Bass Amp D.I. box built in or can use Mic. (prefer DI box)
- 18) Bass Amp to Guitar - Sennheiser Wireless System.

**Guitar Amp:**

- 19) Guitar amp to guitar
- 20) Guitar Effects Pedal

**Vocals:**

- 20) Brandon's Vocals - Boom mic stand & Mic
- 21) Kyle's Vocals - Stand & Mic
- 22) Dave's Vocals - Stand & Mic

**Monitor Mixes:**

**Monitor Mix 1 for Brandon:** Full band mix, heavy on all vocals, from the main vocal mix.....you take off 10 decibels and add your harmony vocals. After that take off another 10 decibels with the guitar mix.

**Monitor Mix 1 for Dave:** Full band mix, heavy on all vocals, from the main vocal mix.....you take off 10 decibels and add your harmony vocals. After that take off another 10 decibels with the guitar mix.

**Monitor Mix 2 for Kyle:** Main vocals on top, backup harmonies -10db, guitar, another -10db from that, heavy bass

**Monitor Mix 3 for Cory:** Full band mix **without** drums, heavy bass